

Rail in a Box
Fitting
Instructions



Components

These instructions are based on a typical 13 tread straight domestic flight and will achieve a 3600mm long wall mounted handrail solution on any straight run of wall.

Before you commence, please identify and check all parts below are present.

- A** 3 x rails 1200mm
- B** 1 x l/h end bracket
- C** 1 x r/h bracket
- D** 2 x intermediate brackets

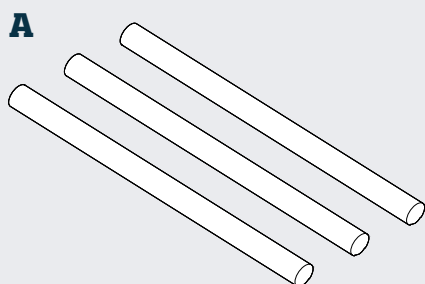

Oak & Pine Wall Patrices
Available Separately



AXPATP
PINE WALL PATRICE



AXPATO
OAK WALL PATRICE

All components should be inspected BEFORE installation commences for any damage and to check all your items are correct before installation. While care is taken to match our engineered timber products, timber is a natural product where the colour, grain structure, can vary.

While we do everything possible to ensure the information contained within these fitting instructions are correct, they are only a general guide, every situation is different. Please read through the fitting instruction fully before commencing any fitting, Cheshire Mouldings will not be held responsible for any mistakes made through incorrect fitting. You will need to take extra care when installing pre-finished components and some touching up will undoubtedly be necessary around the cut areas.

Establish handrail height and location

Measure up vertically 905mm from the nosing on the bottom tread and mark location (**Fig.1**).

Measure up vertically 905mm from the nosing on the top tread and mark location (**Fig.2**). It may be necessary to repeat the same measurement on other tread nosing's on the stairs.

Run a straight line through all the marks on the wall using a straight edge/plumb line. This line will be used to align the top of the handrail to.

Next, find the midpoint of the stairs. If you are installing on a typical 13 tread stairs, the mid point will be level with riser 7 face. Otherwise, measure distance between top and bottom nosing and divide by 2 to get the mid point. Draw a vertical line up so it intersects the 905mm line. This will be used to align the middle rail (**Fig.3**).

Take a rail length and find the point and mark (**Fig.4**). This rail will be used in the middle of the run and the mark will be used to align with the mid point of the stairs.

Fix the intermediate connectors to each end of the marked handrail. Offer the end of the handrail half way into the intermediate connector (**Fig.5**).

Pilot drill through the 2 bracket holes using 3mm bit and fix using screws supplied (**Fig.6**). Repeat at other end of rail.

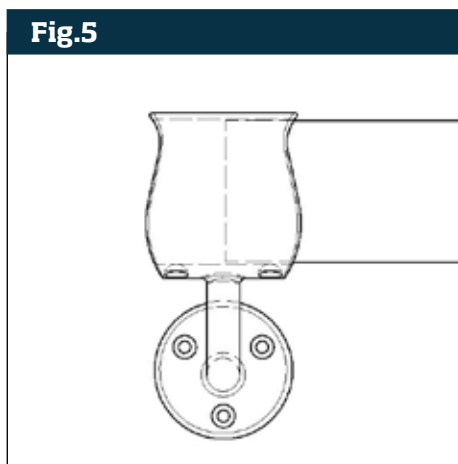
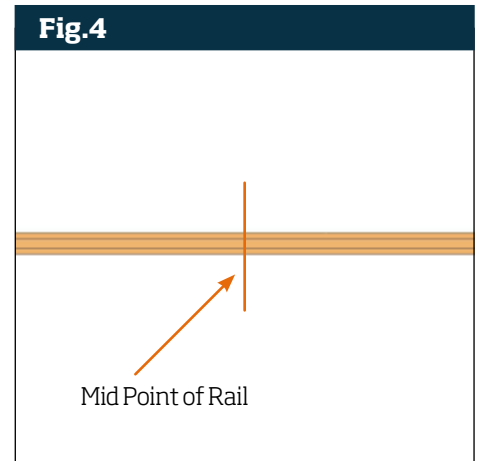
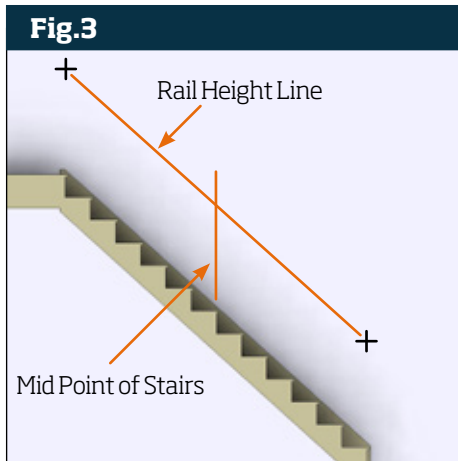
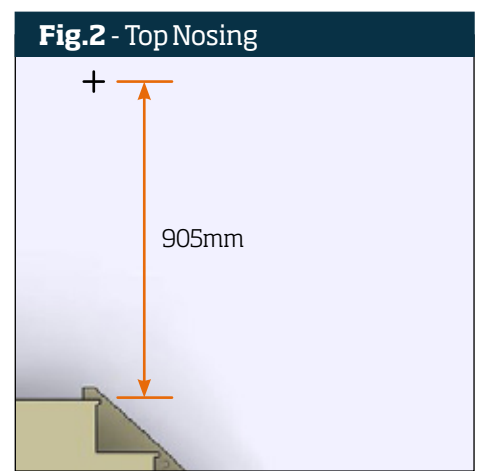
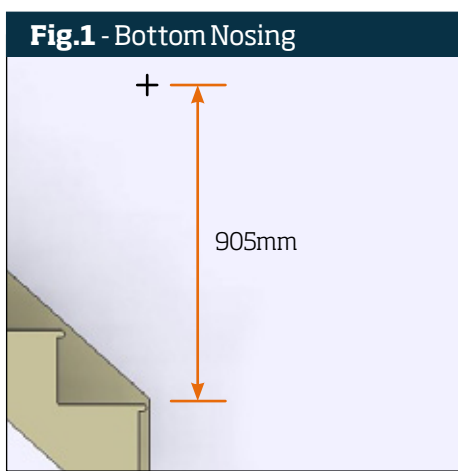

Fitting WITHOUT Patrices

Offer the rail with the intermediate brackets attached at each end to the wall, ensuring that the top of the handrail is aligned with the handrail height line and the mark at the mid-point on the underside of the handrail is aligned with the vertical mid-point line on the stairs (**Fig 7**).

This may require 2 people.

With the rail aligned with the wall lines, mark bracket screw hole locations onto the wall. Drill and plug wall and secure both intermediate brackets to the wall (**Fig 8 & Fig 9**).

Fix an end bracket to the end of a length of handrail. Pilot drill and secure using 2 off screws supplied (**Fig 10**).

Offer the rail assembly fully into intermediate bracket until the rail ends meet. Align top of handrail with handrail height line and mark screw hole locations for end bracket onto wall (**Fig 11**).

Drill, plug and secure end bracket to wall (**Fig 12**).

Secure rail end into intermediate bracket by pilot drilling through 2 x intermediate screw holes and fix in place using screws supplied (**Fig 13**).

Repeat procedure for last rail following steps shown in Figs 10 -13 (**Fig 14**).

Carefully remove any pencil marks from the wall area.

Cleaning of the product can be done with a damp cloth or lint free dry cloth, depending on level of cleaning required. Avoid using heavy detergents as this can damage the finish of the components.

Fig.7

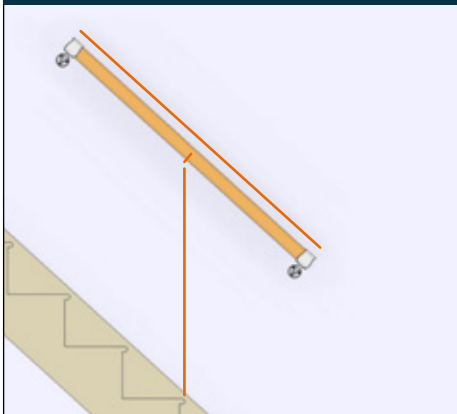

Fig.8



Fig.9



Fig.10

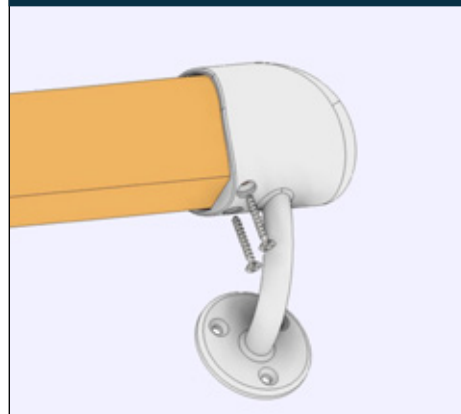

Fig.11

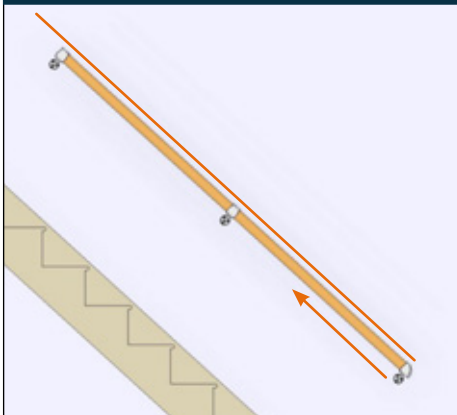

Fig.12

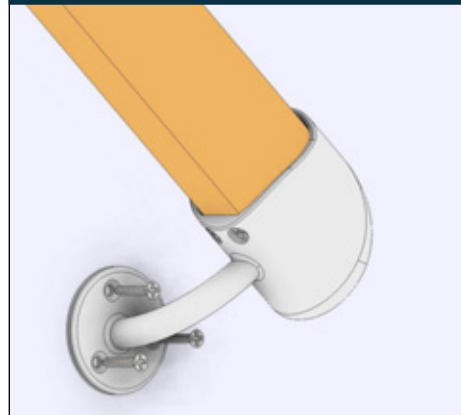

Fig.13

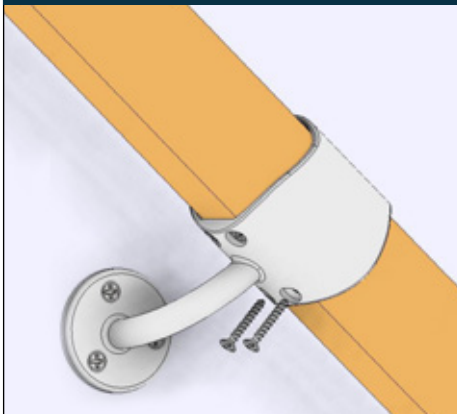
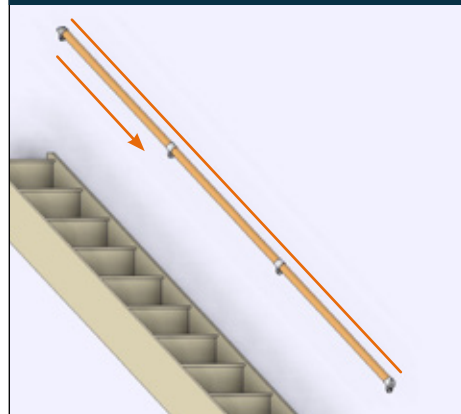

Fig.14



Fitting WITH Patrices

Position a wall patrice centrally against the base of both wall brackets and offer assembly against the wall, ensuring that the top of the handrail is level and aligned with the handrail height line and the mark at the mid point on the underside of the handrail is aligned with the vertical mid point line on the stairs (**Fig.15**). This requires 2 people.

With the rail aligned with the wall marks and the wall bracket base central to the wall patrice, mark location of both patrices on wall. Also, mark bracket screw hole locations through onto patrice (**Fig.16**). Remove assembly.

Drill 2 x clearance hole for fixing screws through the patrice and countersink ensuring they do not conflict with bracket screw hole marks on the patrice. It is not imperative that fixings are hidden beneath the wall bracket base but it does make a tidy job.

Offer patrices up to location marks and drill through clearance holes to mark wall for wall plugs. Drill and plug using fixings suitable for the type of wall being fitted to (**Fig.17**).

Offer the rail and intermediate brackets assembly centrally onto the wall patrices, ensuring the top of the rail and mid point of the rail marks are aligned with the wall marks (**Fig.18**). Pilot drill through wall bracket base screw holes using 3mm dia drill bit and fix to patrices using screws supplied (**Fig.19 & 20**).

To fix rail for the bottom part of the stairs, offer the right hand end bracket onto the end of a handrail. Pilot drill through bracket screw holes using 3mm dia drill bit and secure using screws supplied (**Fig.21**).

Position and hold a patrice centrally to the end bracket base and offer assembly fully into intermediate bracket facing down the stairs ensuring the top of the handrail is aligned to the handrail height line previously marked (**Fig.22**).

Fig.15

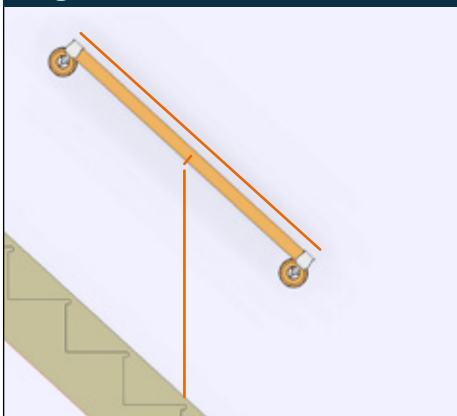

Fig.16

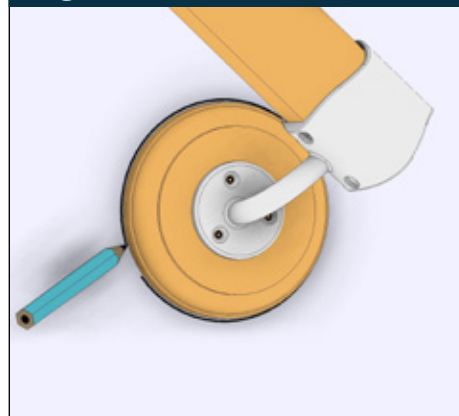

Fig.17

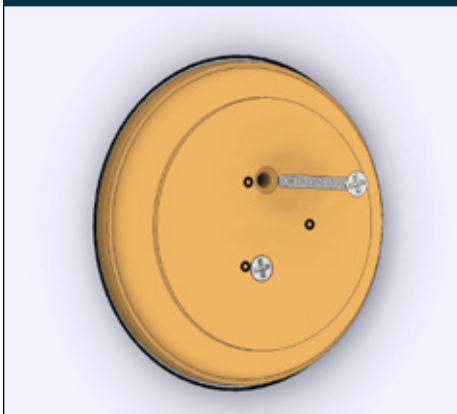

Fig.18

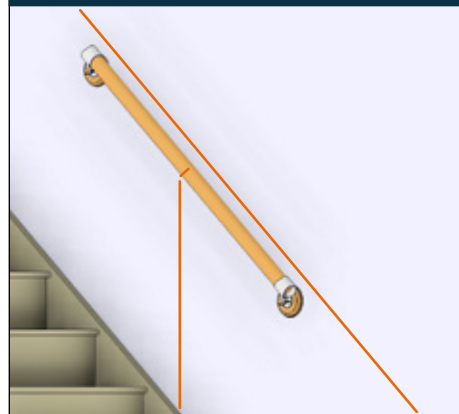

Fig.19

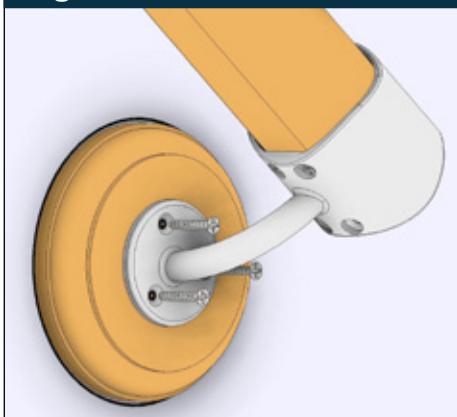

Fig.20

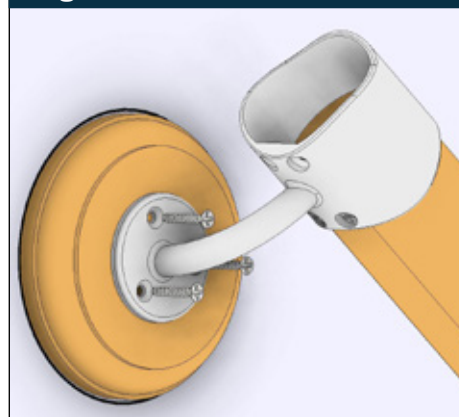

Fig.21

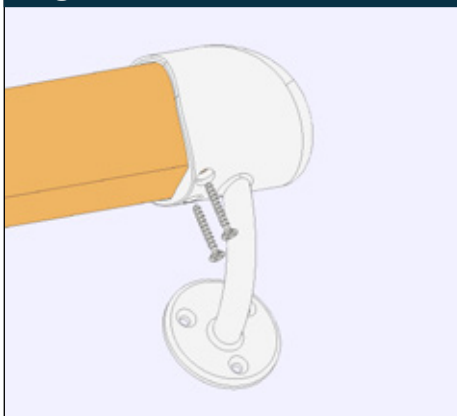
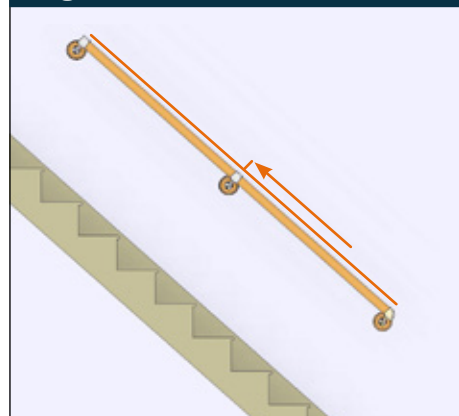

Fig.22



Mark around the patrice location and mark through the bracket screw holes onto the patrice (**Fig.23**). Remove bottom assembly

Drill 2 x clearance hole for fixing screws through the patrice and countersink, ensuring they do not conflict with bracket screw hole marks on the patrice.

Offer patrice up to location mark and drill through clearance holes to mark wall for wall plugs. Drill and plug using fixings suitable for the type of wall being fitted to (**Fig.24**).

Offer the rail and end bracket assembly back into intermediate bracket and locate bracket base centrally onto the bottom wall patrice, ensuring the top of the rail is aligned with the rail height line mark. Pilot drill through wall bracket base screw holes using 3mm dia drill bit and fix to patrice using screws supplied (**Fig.25**).

Secure bottom rail assembly into intermediate bracket by pilot drilling through bracket screw holes and fix using screws supplied (**Fig.26**).

Repeat procedure for assembling and fixing top rail length into position **Figs 21 -26 (Fig 27)**.

Rail in a Box installation is now complete.

Carefully remove any pencil marks from the wall area. Cleaning of the product can be done with a damp cloth or lint free dry cloth, depending on level of cleaning required.

Avoid using heavy detergents as this can damage the finish of the components.

Fig.23

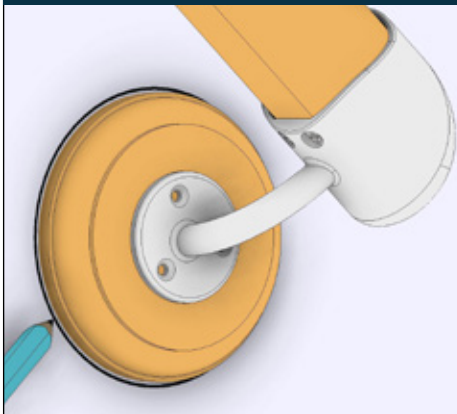

Fig.24

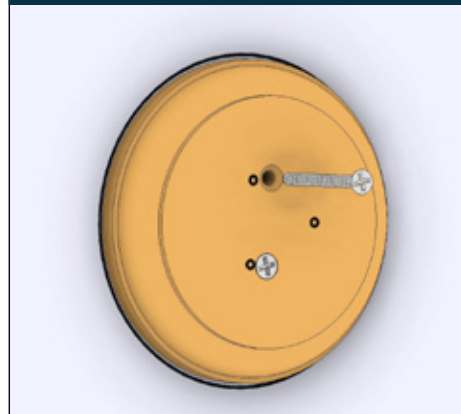

Fig.25

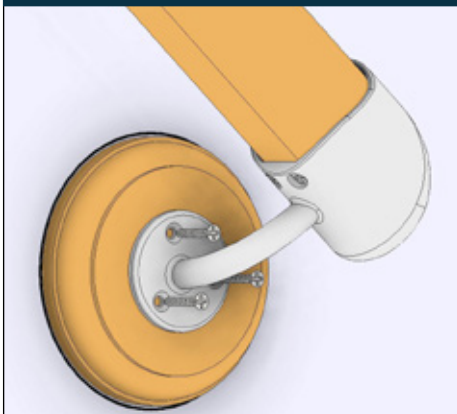

Fig.26

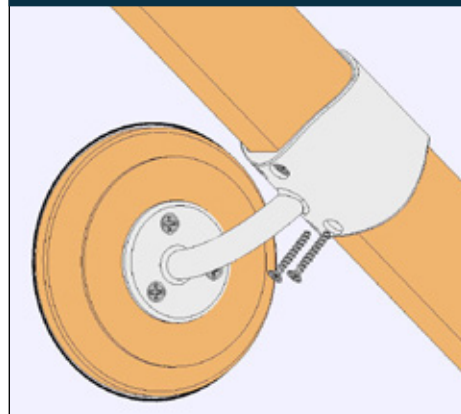
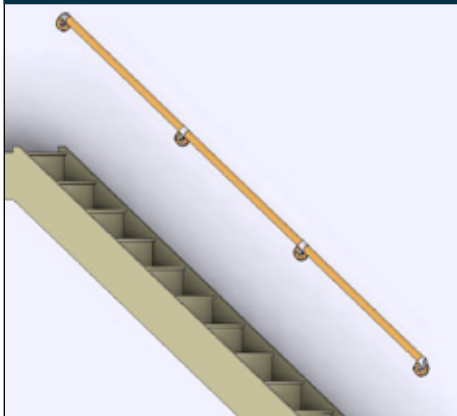

Fig.27





CHESHIRE
mouldings
TRADE

Technical Helpline:
Freephone
0800 085 3475